

Contents

1 - Foreword	3
2 - General characteristics	4
3 - Standard Aircraft Definition	12
4 - Optional equipment	14
5 - Table of Constraints	22
6 - Main performance	25
7 - Customer service overview	39

Manufacturers notice

Attention !

EUROCOPTER, *its logo*, EC120 B, COLIBRI, FENESTRON, SPHERIFLEX, VEMD, STYLENCE are trade marks of the Eurocopter group.

Eurocopter's policy is one of on-going product enhancement which means that alterations in definition, pictures, weights, dimensions or performance may be made at any time without notice being included in those documents that have already been issued.

This document cannot thus be taken as an offer or serve as an appendix to a contract without a prior check as to its validity and prior written agreement of EUROCOPTER.

The operational or certification regulations, as defined by the local authorities, can make compulsory the installation of some of the equipment and recommended solutions, listed in this document. This list does not claim to cover the whole of the worldwide operational requirements nor the equipment not specifically related to the helicopter (for example : life jacket) or necessary for particular missions (for example : supplemental oxygen). The operator is responsible for ascertaining with his local authorities that the planned configuration of the helicopter complies with regulatory requirements for the area(s) of operations and the type(s) of mission(s) considered.

*The data set forth in this document are general in nature and for information purposes only.
For performance data and operating limitations, reference must be made to the approved flight manual and all appropriate documents..*

Blank

*The data set forth in this document are general in nature and for information purposes only.
For performance data and operating limitations, reference must be made to the approved flight manual and all appropriate documents..*

1- Foreword



The COLIBRI EC120 B single-engine helicopter as defined in this Type Specification fulfils the European JAR 27 issue 1 regulation for VFR operation by day and night ¹.

EC120 B is certified with a single pilot being on the right or left side. The standard aircraft is delivered with right side controls (removable dual controls are on option).

The EC120 B design was undertaken with the following goals in mind :

- *Comfortable five-seater, practical, versatile, performing and silent, intended to meet the requirements of the civil and public-services markets.*
- *Competitive selling price*
- *Reduced operating costs*
- *Alleviated and simplified maintenance performed locally by the operator.*

With a Maximum Gross Weight of 1,715 kg / 3,780 lb, the EC120 B is an helicopter of the new generation whose original concept stands out by :

A cost effective use of modern technology

A spacious cabin particularly comfortable and quickly transformable

A user friendly cockpit featuring a Vehicle and Engine Multifunction Display (VEMD) to reduce pilot workload while improving safety and maintenance

A modern design fully compliant with JAR 27 regulation featuring energy absorbing seats for pilot, copilot, passengers as well as a crashworthy fuel system

A modular design of main mechanical components facilitating inspection, replacement and condition checkouts

A TURBOMECA ARRIUS 2F turbine-engine, modular in design and with a low fuel consumption, its maximum take-off power rating at sea level, in ISA conditions, is 376 kW (504 shp – 511 ch).

An extremely low external noise levels which is 6.7 dB below the 85.4 dB required by the ICAO (chapter 11, appendix 4, Annex 16).

¹ *by night, in VFR, when the equipment required by operational regulations are installed and serviceable.*

The data set forth in this document are general in nature and for information purposes only.

For performance data and operating limitations, reference must be made to the approved flight manual and all appropriate documents..

2- General Characteristics

Remarks :

When equipped with appropriate optional equipment, the EC120 B is JAA certified for day and night VFR operations.

The operator shall check current operational regulations of the concerned country.

Lay-Out

- | | |
|-----------------------|---|
| ■ Passenger transport | ■ 1 pilot + 4 passengers
or
2 pilots + 3 passengers |
| ■ Casualty transport | ■ 1 pilot + 1 paramedic
and
1 stretcher-patient |
| ■ Cargo carrying | ■ 1 pilot + 2.94 m ³ (103.82 cu.ft) total useful
load volume (cabin and hold) |

Weights

Note : Empty weight accuracy : within $\pm 2\%$

	kg	lb
■ Empty weight, standard aircraft ¹	965	2,127
■ Useful load ²	750	1,653
■ Maximum take-off weight	1,715	3,781
■ Maximum cargo sling load	700	1,543
■ Maximum operational weight in external load configuration	1,800	3,968

Power plant : 1 TURBOMECA ARRIUS 2 F turbine engine

Engine ratings

Power in ISA at sea level :

	kW	ch	shp
■ Take-off power	376	511	504
■ Maximum continuous power	335	455	449

Usable Fuel capacities

	litres	US gal.	kg	lb
■ Standard fuel tank ³	406	107	321	707

1 Standard aircraft empty weight includes oil and unusable fuel. Ballast plates can be added at the rear of the fenestron, their mass is 19 kg (41,9 lb) maximum.

2 The useful load does not include the ballast plates. Depending on the configuration, the ballast's weight will be deducted from the useful load.

3 The total fuel tank capacity is accurate to ± 5 l.

The data set forth in this document are general in nature and for information purposes only.

For performance data and operating limitations, reference must be made to the approved flight manual and all appropriate documents..

Main dimensions

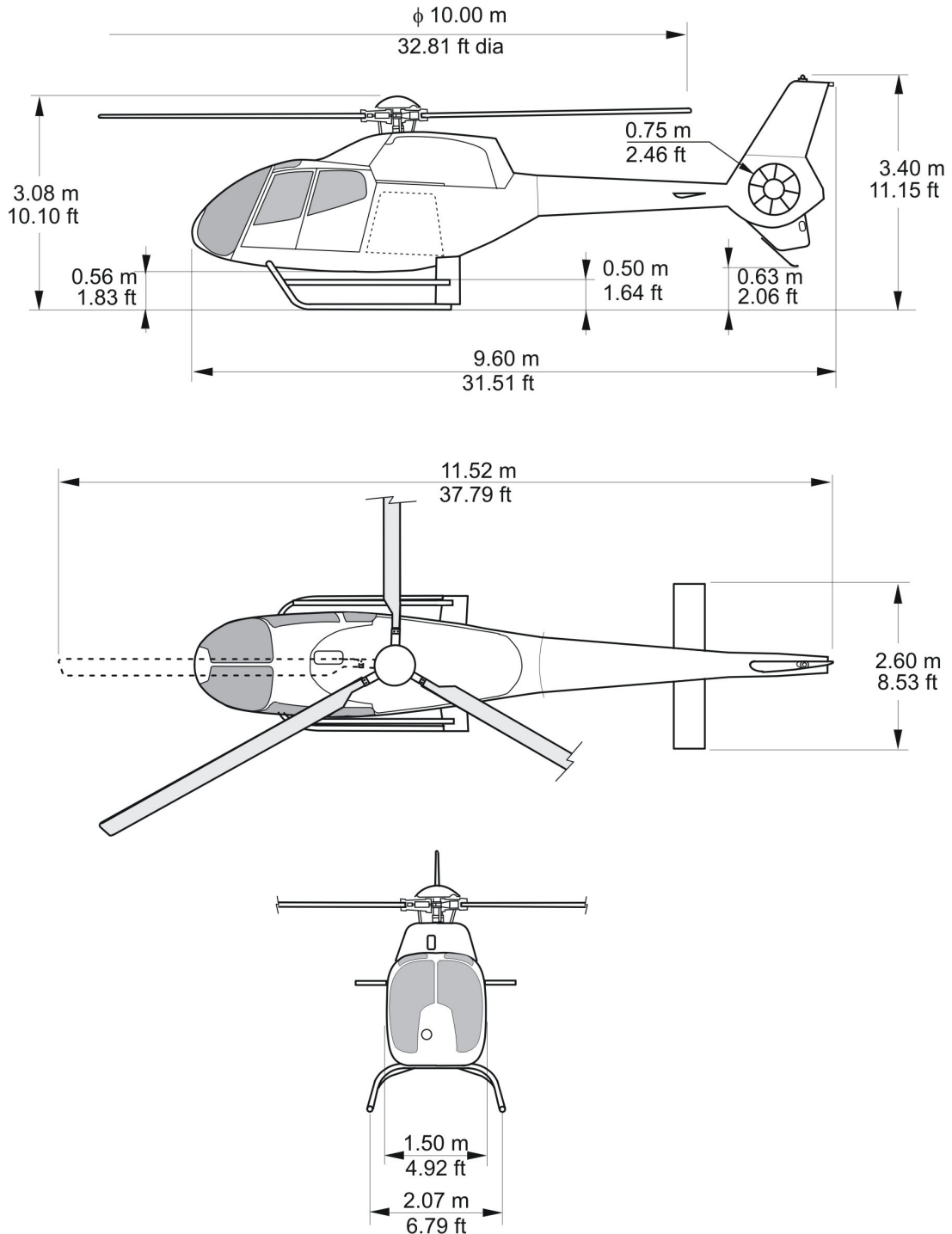

Dimensions given for information only

The data set forth in this document are general in nature and for information purposes only.

For performance data and operating limitations, reference must be made to the approved flight manual and all appropriate documents..

Configurations

A roomy cabin with outstanding comfort



The *EC120 B* benefits from a roomy cabin and exceptional glazed surface providing the passengers an excellent comfort and a very good field of view.



Note : EC120 B in standard upholstery configuration.



Note : Removable parts of the dual controls are optional.

The data set forth in this document are general in nature and for information purposes only.

For performance data and operating limitations, reference must be made to the approved flight manual and all appropriate documents..



The luggage compartment is able to contain up to 5 large suitcases. When the helicopter is configured for internal freight transport, the cabin area plus luggage compartment make loading and unloading effortless thanks to an unobstructed cabin and a flat floor.

A new generation of light single engine helicopter

The *EC120 B* includes the latest technologies that will make piloting easier and safer.

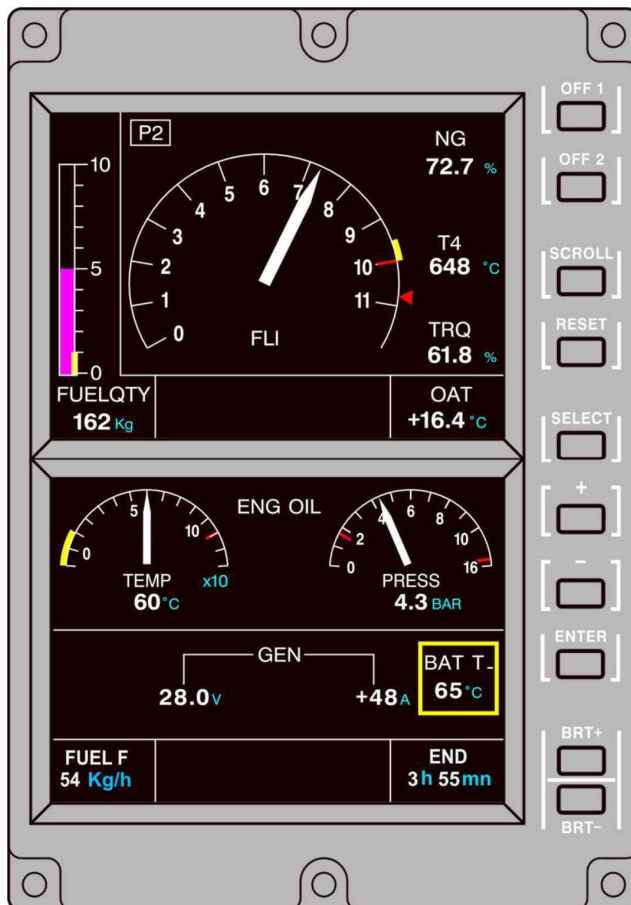

The *VEMD* (Vehicle and Engine Multifunction Display) is a fully duplex equipment which displays on LCD screen 3 operating modes :

- the operational mode,
- the configuration mode,
- the maintenance mode.

The *VEMD* is easy to maintain thanks to its modular design.

The data set forth in this document are general in nature and for information purposes only.

For performance data and operating limitations, reference must be made to the approved flight manual and all appropriate documents..

The Main Rotor :



The main rotor generates the lift and the traction transferred to the helicopter. During flight, it allows the helicopter to be controlled in roll and pitch in conjunction with the tail rotor (yaw).

The main rotor assembly includes :

- The main rotor head and mast,
- The main rotor blades.

Rotor head *SPHERIFLEX* type : this highly reliable rotor head is very easy to maintain.

The Main Rotor Blades :

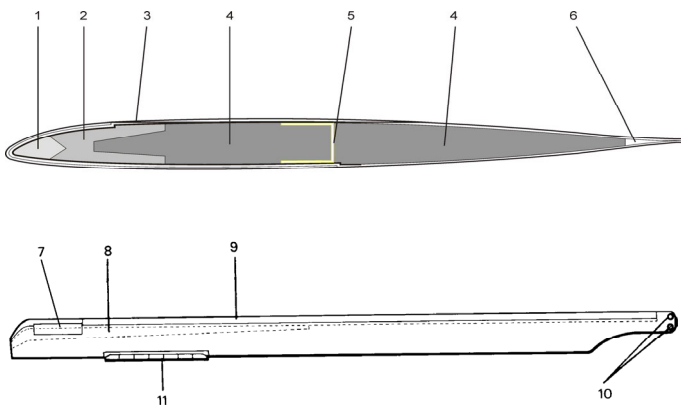

Main rotor blades are aerodynamically optimized. They are corrosion proof and highly tolerant to impacts.

- 1 Lead balancing weight
- 2 Roving spar
- 3 Fiberglass cloth skin
- 4 Foam filler
- 5 Carbon fabric rib
- 6 Roving edge
- 7 Balancing weight chamber
- 8 Polyurethane strip
- 9 Stainless steel plate
- 10 Stainless steel bushings
- 11 Tabs

Individually interchangeable, they are made of composite materials and secured to the hub with special bolts.

The Tail Rotor Blades :

Third generation of *FENESTRON* with airfoil and 8 asymmetrical blades spacing for low noise emission.

This *FENESTRON* is integrated into a composite structure.



The data set forth in this document are general in nature and for information purposes only.

For performance data and operating limitations, reference must be made to the approved flight manual and all appropriate documents..

A modern and efficient Power Plant :

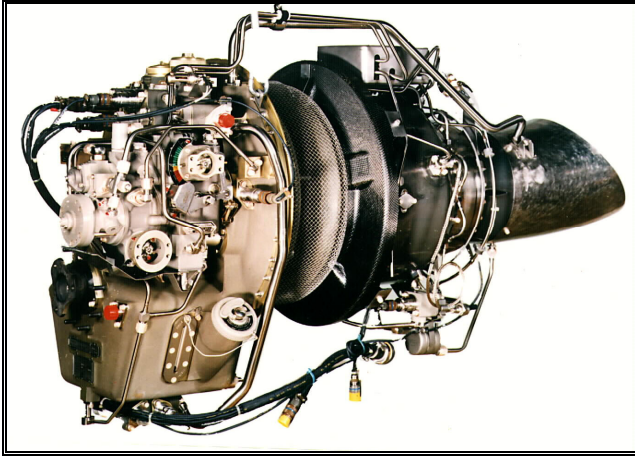

The ARRIUS 2F is the latest engine generation of Arrius family (from TURBOMECA) which combines power (504 shp), simplicity (2 modules), low fuel consumption and benefits from the wide experience of the Arrius engine family.

The turbine engine is mounted at the top of the rear structure, in a fireproof compartment. It is installed at the rear of the main gearbox, to which it is linked by a connecting shaft mounted between two blade-type flexible couplings.

The TURBOMECA ARRIUS 2F free turbine engine is composed of 2 modules as follows :

Module 1 (reduction gearbox) : it consists of a reduction gear unit including an oil tank and accessory box assembly.

Module 2 (gas generator and power turbine) : the Module 2 comprises an air intake casing, a centrifugal compressor, a combustion chamber, a high pressure turbine (HP turbine), a power turbine and a power transmission shaft and outlet diffuser.

The data set forth in this document are general in nature and for information purposes only.

For performance data and operating limitations, reference must be made to the approved flight manual and all appropriate documents..

Instrument panel :

Standard instrument panel



Fully equipped instrument panel



Slaving Control and Compensation Unit *
Emergency Locator Transmitter control unit *
VEMD (Vehicle and Engine Multifunction Display)
NR/NF dual indicator
CWP (Central Warning Panel)
Altimeter
Gyro horizon *

Airspeed indicator
Quartz Chronometer *
Horizontal Situation Indicator *
Vertical speed indicator *
DME indicator *
Combined VHF-AM / VOR / LOC / GS / GPS *
Landing light indicator light

* Optional

The data set forth in this document are general in nature and for information purposes only.

For performance data and operating limitations, reference must be made to the approved flight manual and all appropriate documents..

Dimensions of compartments and accesses

- Cabin main dimensions

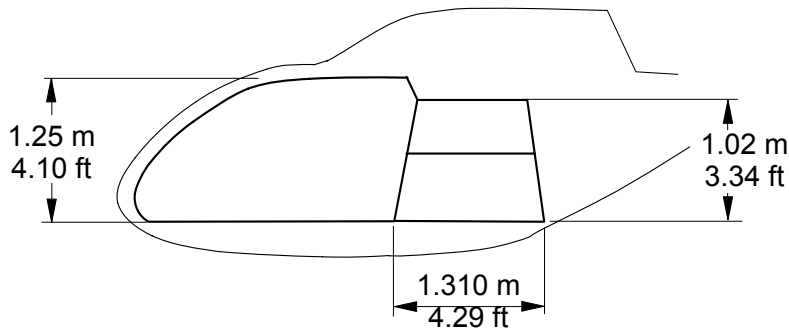

CABIN	
Surface	1.91 m ² 20.56 ft ²
Volume	2.14 m ³ 75.57 ft ³

- Cabin and cargo compartment areas

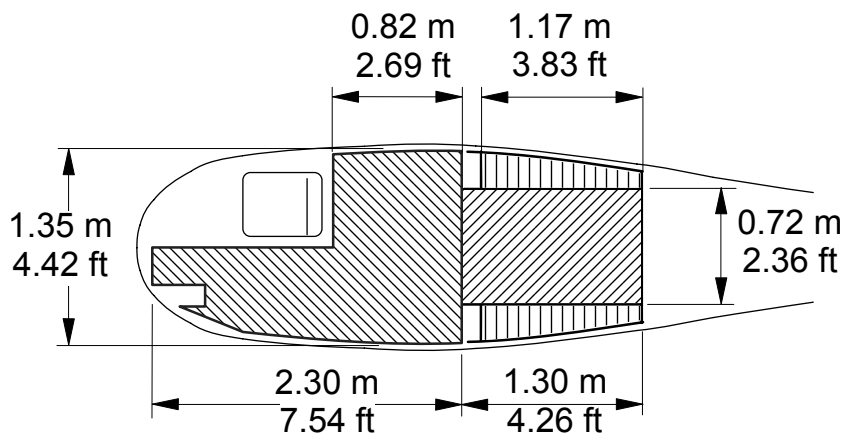

CARGO COMPARTMENT	
Surface	1.40 m ² 15.07 ft ²
Volume	0.80 m ³ 28.25 ft ³

- Doors dimensions

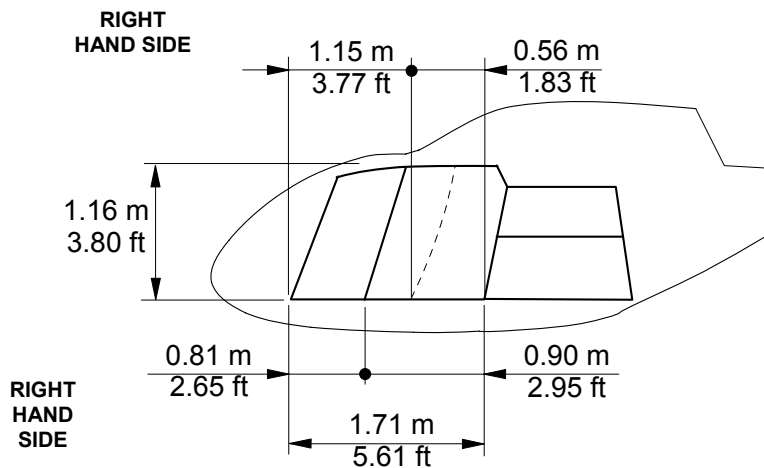

The data set forth in this document are general in nature and for information purposes only.

For performance data and operating limitations, reference must be made to the approved flight manual and all appropriate documents..

3- EC120 B - Standard Aircraft Definition

GENERAL

- The EC120 B is certified with a pilot being on the right or left side
- The standard aircraft is delivered with right side controls and fixed parts of the removable dual controls (the removable parts of removable dual controls are optional)
- Fuselage comprising the cabin and the luggage hold with several accesses possibilities
- Tail boom with stabilizer, "built in" vertical fin anti-torque rotor (*FENESTRON*[®] type)
- High skid landing gear compatible with handling wheels
- Lifting points
- Mooring fixtures
- Interior signs and markings : available in French or English
- External paint : fuselage in single color paint to be selected among Eurocopter referenced and qualified paints. Main rotor head and tail rotor covers are painted in grey, skid landing gear in dark grey and *FENESTRON*[®] duct in light grey
- Internal paint :
 - light grey : (prevailing colour)
 - black : (flight controls, glare shield, central console, upper controls quadrant,)

CABIN / CARGO

- Same level cabin/cargo floor
- 2 pilot and copilot energy absorbing seats, adjustable in reach, removable, complete with cushions, safety belts and shoulder harnesses
- 1 three place energy absorbing rear bench seat quickly removable with cushions, safety belts with shoulder strap
- 2 pilot and copilot jettisonable doors fitted with a sliding window and a deflector
 - 1 RH front large door
 - 1 LH front door
- 1 RH rear fixed panel
- 1 LH rear sliding door
- 1 footstep on landing gear
- Lateral and upper bronze tinted windows (windscreen excluded)
- 1 communication panel quickly removable between cabin and cargo compartment
- 1 right lateral hinged cargo door
- 1 rear hinged access cargo door
- 1 ceiling housing the ventilation/demisting/heating (optional air conditioning) ducts, shut-off valve and rotor brake controls and the cabin lighting circuit
- 1 removable plug on cabin ceiling duct (ram air ventilation and heating in summer configuration)
- Capabilities for optional equipment (such as wire strike protection system, windshield wiper ...)
- 1 fire-extinguisher
- 1 Flight Manual

INSTRUMENTS

- Instruments units available in English units only (altimeter in feet and airspeed indicator in kts)
- 1 airspeed indicator
- 1 altimeter
- 1 self powered rotor and free turbine tachometer dual indicator (NR/NF)
- 1 central warning panel (warning, caution, with MGB/TGB chip indication annunciators)
- 1 stand-by magnetic compass
- 1 heated pitot head
- 1 external side slip indicator
- 1 control box for light and electrical generation (LACU)
- 1 cockpit breaker panel
- 1 cargo circuit breaker panel
- 1 LCD Dual screen Vehicle and Engine Multifunction Display (*VEMD*[®]) providing the following information:
 - First limitation indicators (FLI)
 - ◆ torquemeter
 - ◆ exhaust gas temperature (T4)
 - ◆ gas generator tachometer (Ng, delta Ng)
 - Engine oil temperature/pressure
 - Fuel quantity
 - Ammeter, voltmeter and battery temperature
 - Outside Air Temperature (OAT)
 - Enhanced usage monitoring functions
 - ◆ IGE/OGE performance calculations
 - ◆ engine cycle counting
 - ◆ engine power check
 - ◆ overlimits display
 - *VEMD*[®] and peripheral maintenance information
 - Data downloading capability (softwares and connection wire as options)

POWER PLANT

- 1 TURBOMECA ARRIUS 2F 376 kW (511 ch - 504 shp) turbine engine complete with starting, fuel supply and governing systems and fitted with electrical chip detectors
- 1 fuel system including 2 tanks with a total usable fuel capacity of 406 ± 5 liters (107.3 US gal)
- 1 twist throttle with starter button incorporated in collective lever
- 1 engine lubrication and oil cooling system
- 1 fire detection system
- Engine sensors (Ng, T4, Torque, oil Pressure and Temperature)

The data set forth in this document are general in nature and for information purposes only.

For performance data and operating limitations, reference must be made to the approved flight manual and all appropriate documents..

TRANSMISSION SYSTEM

- 1 main gearbox with oil sight gauge, electrical chip detector, oil temperature and pressure switches, ports for boroscope, self-sealing valve for oil sampling and draining
- 1 engine to main gearbox coupling shaft
- 1 rotor brake
- 1 main rotor high and low r.p.m. warning device
- 1 rear tail drive with low maintenance level
- 1 tail gearbox with oil sight gauge, electrical chip detector and port for boroscopic inspection

ROTORS AND FLYING CONTROLS

- 3 main rotor blades of composite material
- 1 SPHERIFLEX[®] rotor head with droop stops
- 1 anti-torque rotor (FENESTRON[®]) with 8 blades, integrated in vertical fin
- 1 flight control set assisted by 3 main rotor servo units for the main rotor.

ELECTRICAL INSTALLATION

- One 4.8 kW, 28 V DC starter – generator APC
- 1 nickel-cadmium battery
- 1 flashing anti-collision light
- 3 position lights
- 1 fixed landing light with indicator light on instrument panel
- 1 ground power receptacle
- Instrument panel lighting system by fixed spot light on overhead panel (VFR night)
- Integrated lighting in central console
- 2 swivelling emergency and reading map lights for pilot and copilot
- 1 dome light for passengers

AIRBORNE KIT (*)

- 1 pitot head cover
- 2 static port stoppers
- 1 engine exhaust pipe cover
- 1 air intake plug (over cabin)
- 2 ground handling wheels
- 2 mooring rings
- 3 main-blade socks
- 1 document holder
- 1 airborne kit storage bag
- 1 removable plug for air intake scoop on forward cowl (cabin-air recirculation heating in winter configuration)

(*) (weight not included in standard aircraft empty weight)

The data set forth in this document are general in nature and for information purposes only.

For performance data and operating limitations, reference must be made to the approved flight manual and all appropriate documents..

4- Optional equipment

Symbol  shown beside an item denotes some constraint (see table on page 22)

4-1 Mission recommended equipment list :

Eurocopter proposes in the following pages four mission recommended lists for the *EC120 B COLIBRI* :

- 1 **Passenger transport mission**
- 2 **Corporate mission (*STYLENCE*)**
- 3 **Training mission**
- 4 **Utility mission**

The purpose of these mission equipment recommended lists is to partially match typical operational requirements.

Every mission recommended list proposes a batch of options, including the avionics package. It must be considered as a basis for a quick approach of the functions required in operation.

The data set forth in this document are general in nature and for information purposes only.

For performance data and operating limitations, reference must be made to the approved flight manual and all appropriate documents..

1 – RECOMMENDED LIST FOR PASSENGER TRANSPORT MISSION

		Name
EC120 B 06.100.01.E		Standard aircraft
<i>Document reference</i>	<i>Commercial reference</i>	
05-37001-A	05-37001-00-RP	Removable dual controls – Removable Parts
05-44001-A	05-44001-00-CI	Cabin fan ¹
05-85001-A	05-85001-00-CI	Fuel flowmeter
06-67035-A	06-67035-00-CI	Emergency Locator Transmitter Kannad 406 AF-H ^{2 - 3}
07-30001-A	07-30001-00-CI	Comfortable cabin upholstery ⁴
07-40001-A	07-40001-00-CI	Cabin carpet ⁵
08-00021-B	08-00021-01-CI	<u>Avionics package</u> : VHF/AM No.2 Honeywell KY 196 ASC+ I.C.S. and passengers interphone Garmin GMA 340H ⁶ Transponder Garmin GTX 330 (mode S) with altitude encoder Shadin 8800 T ⁷ VHF-AM / VOR / LOC / GS / GPS Garmin GNS 430 ⁸ Gyro-compass Honeywell KCS 55A with HSI KI 525A, and navigation coupling ⁹ Gyro-horizon with slip indication included Thales H321 EGM
08-18016-A	08-18016-00-CI	Headset David Clark H 10-13H ¹⁰
08-62006-A	08-62006-00-CI	Vertical Speed Indicator in feet/mn united Instruments
08-93003-A	08-93003-01-CI	Quartz chronometer, Thommen with digital display
Passenger transport mission equipped empty weight		1016 kg 2239 lb

The aircraft equipped empty weight is correct to ± 2 %

- 1** Can be replaced by the air conditioning system.
- 2** 3 frequencies : 121.5 MHz, 243 MHz, 406 MHz. Compliant with ED 62 and TSO C91A.
The Programming Data Sheet must be filled and communicated by the customer two months at the latest before the helicopter's delivery. May be a mandatory equipment, required by local airworthiness authorities.
- 3** Can be replaced by Emergency Locator Transmitter Kannad 121 AF-H (2 frequencies).
- 4** Cabin carpet, washable cover and reinforced soundproofing are not included in the option.
- 5** Can be replaced by Cabin washable cover.
- 6** Mandatory optional to be proposed with, at least, 2 headsets.
- 7** Can be replaced by Transponder Garmin GTX 327 (mode A and C only).
- 8** A frequencies selector is fitted on the cyclic stick.
Delivered with Europe Navdata card. Subscription to be made by customer in good time for the helicopter delivery.
- 9** The gyro-compass comprises:
one directional gyro with one magnetic azimuth transmitter and one slaving accessory, one HSI indicator KI 525A, one switch GPS/VOR, one GPS caption panel one coupling with the GPS.
- 10** Quantity recommended = 2
The ICS plugs are available in US standard version only and high level/high impedance.

*The data set forth in this document are general in nature and for information purposes only.
For performance data and operating limitations, reference must be made to the approved flight manual and all appropriate documents..*

2 – RECOMMENDED LIST FOR CORPORATE TRANSPORT MISSION (STYLENCE)

		Name
EC120 B 06.100.01.E		Standard aircraft
<i>Document reference</i>	<i>Commercial reference</i>	
05-02034-A	05-02034-00-CI	Multicolor external painting (4 to 6 instead of single color paint) ¹
05-37001-A	05-37001-00-RP	Removable dual controls – Removable Parts
05-42001-B	05-42001-01-CI	Air conditioning system
05-85001-A	05-85001-00-CI	Fuel flowmeter
06-67035-A	06-67035-00-CI	Emergency Locator Transmitter Kannad 406 AF-H ^{2 - 3}
07-00006-B	07-00006-01-CI	STYLENCE cabin layout ⁴
07-60001-A	07-60001-00-CI	Cargo compartment upholstery
08-00021-B	08-00021-01-CI	<u>Avionics package</u> : VHF-AM n° 2 Honeywell KY 196 ASC+ I.C.S. and passengers interphone Garmin GMA 340H ⁵ Transponder Garmin GTX 330 (mode S) with altitude encoder Shadin 8800 T ⁶ VHF-AM / VOR / LOC / GS / GPS Garmin GNS 430 ⁷ Gyro-compass Honeywell KCS 55A with HSI KI 525A, and navigation coupling ⁸ Gyro-horizon with slip indication included Thales H321 EGM
08-18016-A	08-18016-00-CI	Headset David Clark H 10-13H ⁹
08-62006-A	08-62006-00-CI	Vertical Speed Indicator in feet/mn United Instruments
08-93003-A	08-93003-01-CI	Quartz chronometer, Thommen with digital display
Corporate transport mission (STYLENCE) equipped empty weight		1059 kg 2334 lb

The STYLENCE layout is available in one of the following 4 colour schemes :

- Brick - Camel - Graphite - Silver

The aircraft equipped empty weight is correct to ± 2 %

- 1** Registration number, simple national emblem and/or simple logo included, colors to be selected among EUROCOPTER referenced and qualified paints. Can be replaced by other external paint option.
- 2** 3 frequencies : 121.5 MHz, 243 MHz, 406 MHz. Compliant with ED 62 and TSO C91A. The Programming Data Sheet must be filled and communicated by the customer two months at the latest before the helicopter's delivery. May be a mandatory equipment, required by local airworthiness authorities.
- 3** Can be replaced by Emergency Locator Transmitter Kannad 121 AF-H (2 frequencies).
- 4** This layout includes already the optional Comfortable cabin upholstery.
- 5** Mandatory optional to be proposed with, at least, 2 headsets. The ICS plugs are available in US standard version only and high level/high impedance.
- 6** Can be replaced by Transponder Garmin GTX 327 (mode A and C only).
- 7** A frequencies selector is fitted on the cyclic stick. Delivered with Europe Navdata card. Subscription to be made by customer in good time for the helicopter delivery.
- 8** The gyro-compass comprises :
one directional gyro with one magnetic azimuth transmitter and one slaving accessory, one HSI indicator KI 525A, one switch GPS/VOR, one GPS caption panel one coupling with the GPS.
- 9** Quantity recommended = 2
The ICS plugs are available in US standard version only and high level/high impedance.

The data set forth in this document are general in nature and for information purposes only.

For performance data and operating limitations, reference must be made to the approved flight manual and all appropriate documents..

3 – RECOMMENDED LIST FOR TRAINING MISSION

		Name
EC120 B 06.100.01.E		Standard aircraft
Document reference	Commercial reference	
05-21001-A	05-21001-00-CI	Wire strike protection system
05-37001-A	05-37001-00-RP	Removable dual controls – Removable Parts
05-44001-A	05-44001-00-CI	Cabin fan ¹
05-85001-A	05-85001-00-CI	Fuel flowmeter
06-11003-A	06-11003-00-CI	Long Protective skid shoes ²
06-26001-A	06-26001-00-CI	External electric rear view mirror (recommended for sling work)
06-27001-A	06-27001-00-FP	Cargo sling - Fixed parts
06-67035-A	06-67035-00-CI	Emergency Locator Transmitter Kannad 406 AF-H ^{3 - 4}
08-00021-B	08-00021-01-CI	<u>Avionics package</u> : VHF-AM n° 2 Honeywell KY 196 ASC+ I.C.S. and passengers interphone Garmin GMA 340H ⁵ Transponder Garmin GTX 330 (mode S) with altitude encoder Shadin 8800 T ⁶ VHF-AM / VOR / LOC / GS / GPS Garmin GNS 430 ⁷ Gyro-compass Honeywell KCS 55A with HSI KI 525A, and navigation coupling ⁸ Gyro-horizon with slip indication included Thales H321 EGM
08-18016-A	08-18016-00-CI	Headset David Clark H 10-13H ⁹
08-62006-A	08-62006-00-CI	Vertical Speed Indicator in feet/mn United Instruments
08-93003-A	08-93003-01-CI	Quartz chronometer, Thommen with digital display
Training mission equipped empty weight		1014 kg 2235 lb

The aircraft equipped empty weight is correct to ± 2%

- 1** Can be replaced by the air conditioning system.
- 2** Recommended for training missions on non-prepared airfield, can be replaced by short protective skid shoes.
- 3** 3 frequencies : 121.5 MHz, 243 MHz, 406 MHz. Compliant with ED 62 and TSO C91A.
The Programming Data Sheet must be filled and communicated by the customer two months at the latest before the helicopter's delivery. May be a mandatory equipment, required by local airworthiness authorities.
- 4** Can be replaced by Emergency Locator Transmitter Kannad 121 AF-H (2 frequencies).
- 5** Mandatory optional to be proposed with, at least, 2 headsets.
- 6** Can be replaced by Transponder Garmin GTX 327 (mode A and C only).
- 7** A frequencies selector is fitted on the cyclic stick.
Delivered with Europe Navdata card. Subscription to be made by customer in good time for the helicopter delivery.
- 8** The gyro-compass comprises:
one directional gyro with one magnetic azimuth transmitter and one slaving accessory, one HSI indicator KI 525A, one switch GPS/VOR, one GPS caption panel one coupling with the GPS.
- 9** Quantity recommended = 2
The ICS plugs are available in US standard version only and high level/high impedance.

*The data set forth in this document are general in nature and for information purposes only.
For performance data and operating limitations, reference must be made to the approved flight manual and all appropriate documents..*

4 – RECOMMENDED LIST FOR UTILITY MISSION

		Name
EC120 B 06.100.01.E		Standard aircraft
<i>Document reference</i>	<i>Commercial reference</i>	
05-37001-A	05-37001-00-RP	Removable dual controls – Removable Parts
05-44001-A	05-44001-00-CI	Cabin fan ¹
06-26001-A	06-26001-00-CI	External electric rear view mirror (recommended for sling work)
06-27001-A	06-27001-00-FP	Cargo sling - Fixed parts
06-27001-A	06-27001-00-RP	Cargo sling – Removable parts
06-67035-A	06-67035-00-CI	Emergency Locator Transmitter Kannad 406 AF-H ^{2 - 3}
08-00021-B	08-00021-01-CI	Avionics package : VHF-AM n° 2 Honeywell KY 196 ASC+ I.C.S. and passengers interphone Garmin GMA 340H ⁴ Transponder Garmin GTX 330 (mode S) with altitude encoder Shadin 8800 T ⁵ VHF-AM / VOR / LOC / GS / GPS Garmin GNS 430 ⁶ Gyro-compass Honeywell KCS 55A with HIS KI 525A, and navigation coupling ⁷ Gyro-horizon with slip indication included Thales H321 EGM
08-18016-A	08-18016-00-CI	Headset David Clark H 10-13H ⁸
08-62006-A	08-62006-00-CI	Vertical Speed Indicator in feet/mn United Instruments
08-93003-A	08-93003-01-CI	Quartz chronometer, Thommen with digital display
Utility mission equipped empty weight		1012 kg 2230 lb

The aircraft equipped empty weight is correct to ± 2 %

- 1** Can be replaced by the air conditioning system.
- 2** 3 frequencies : 121.5 MHz, 243 MHz, 406 MHz. Compliant with ED 62 and TSO C91A.
The Programming Data Sheet must be filled and communicated by the customer two months at the latest before the helicopter's delivery. May be a mandatory equipment, required by local airworthiness authorities.
- 3** Can be replaced by Emergency Locator Transmitter Kannad 121 AF-H (2 frequencies).
- 4** Mandatory optional to be proposed with, at least, 2 headsets.
- 5** Can be replaced by Transponder Garmin GTX 327 (mode A and C only).
- 6** A frequencies selector is fitted on the cyclic stick.
Delivered with Europe Navdata card. Subscription to be made by customer in good time for the helicopter delivery.
- 7** The gyro-compass comprises :
one directional gyro with one magnetic azimuth transmitter and one slaving accessory, one HSI indicator KI 525A, one switch GPS/VOR, one GPS caption panel one coupling with the GPS.
- 8** Quantity recommended = 2
The ICS plugs are available in US standard version only and high level/high impedance.

*The data set forth in this document are general in nature and for information purposes only.
For performance data and operating limitations, reference must be made to the approved flight manual and all appropriate documents..*

4-2 List of optional equipment

If any, the potential incompatibilities between some items of optional equipment are summarized in the Chapter 5.

Note : value of the weight breakdown is given for information and shall not be considered as contractual.

General equipment

	Document reference	Commercial reference	Name	kg	lb
⚠	05-02002-A	05-02002-00-CI	Aircraft without external paint ^{1 - 2}	-6.5	-14.3
⚠	05-02028-A	05-02028-00-CI	Landing gear customized paint ³	TBD	TBD
⚠	05-02033-A	05-02033-00-CI	Two or three-color external painting instead of single color paint ⁴	TBD	TBD
⚠	05-02034-A	05-02034-00-CI	Multicolor external painting (4 to 6 instead of single color paint) ⁴	TBD	TBD
⚠	05-02035-A	05-02035-00-CI	Highly customized paint ⁵	TBD	TBD
	05-03011-A	05-03011-00-CI	First-aid kit - JAR OPS 3 Compatible ⁶	2.7	5.9
	05-21001-A	05-21001-00-CI	Wire strike protection system	5.0	11.0
	05-23001-A	05-23001-00-CI	Engine washing device	0.2	0.4
	05-24001-A	05-24001-00-CI	Concentric high visibility on main rotor blades (red, white or yellow strips) ⁷	0.1	0.2
	05-25001-A	05-25001-00-CI	Sand filter	5.7	12.6
	05-32004-A	05-32004-00-CI	Windshield wipers ⁸	3.7	8.2
	05-37001-A	05-37001-00-RP	Removable dual controls - Removable Parts ⁹	5.6	12.3
	05-37004-A	05-37004-00-CI	Full-option pilot cyclic control stick (right side)	1.0	2.2
	05-37005-A	05-37005-00-CI	Full-option co-pilot cyclic control stick (left side)	0.7	1.5
	05-41006-A	05-41006-00-CI	Extreme cold weather cabin heating	8.5	18.7
⚠	05-42001-B	05-42001-01-CI	Air conditioning system	27.4	60.4
⚠	05-44001-A	05-44001-00-CI	Cabin fan ¹⁰	2.5	5.5
	05-61001-A	05-61001-00-CI	Battery heating for very cold weather starting kit	0.5	1.1
	05-63004-A	05-63004-00-CI	AUXILEC electrical generation instead of standard APC electrical generation	0.0	0.0
	05-71000-A	05-71000-00-CI	Hydraulic ground power receptacle	0.2	0.4
	05-85001-A	05-85001-00-CI	Fuel flowmeter	0.7	1.5
	05-91001-A	05-91001-00-CI	Handling twin-wheel units with hydraulic jacking system ¹¹	40.6	89.5

1 Subject to prior authorization of local airworthiness authorities.

2 Dropping value applicable to the standard aircraft.

3 Choice of the color to be specified on order.

4 Registration number, simple national emblem and/or simple logo included, colors to be selected among EUROCOPTER referenced and qualified paints.

5 4 colors and more selected among Eurocopter referenced and qualified paints.

Sophisticated emblem/logo/armorial bearings.

Selected paint(s) not referenced nor qualified by EUROCOPTER subject to acceptance

6 Its content is the buyer's responsibility as it may vary according to geographical region or applicable regulation.

7 Choice of the color to be specified on order.

8 The optional consists of : one pilot's windshield wiper and one copilot's windshield wiper.

9 The EC120 B standard aircraft has the capability (FP included) of the dual controls.

10 Mandatory optional unless replaced by the air conditioning system.

11 Replaces the handling wheels delivered with the airborne kit.

The data set forth in this document are general in nature and for information purposes only.

For performance data and operating limitations, reference must be made to the approved flight manual and all appropriate documents..

Specific mission equipment

Document reference	Commercial reference	Name	kg	lb
⚠ 06-11001-A	06-11001-00-FP	Skis – Fixed Parts	1.1	2.4
	06-11001-00-RP	Skis – Removable Parts	10.7	23.6
⚠ 06-11002-A	06-11002-00-CI	Short protective skid shoes ¹	2.5	5.5
	Or	Or	or	or
⚠ 06-11003-A	06-11003-00-CI	Long protective skid shoes ²	6.4	14.1
	06-26001-A	06-26001-00-CI	External electric rear view mirror ³	2.4
06-27001-A	06-27001-00-FP	Cargo sling – Fixed Parts	3.4	7.5
	06-27001-00-RP	Cargo sling – Removable Parts	8.4	18.5
06-42014-A	06-42014-00-CI	Swivelling landing light ⁴	3.2	7.1
⚠ 06-61001-A	06-61001-00-FP	Emergency floatation gear – Fixed Parts	3.2	7.1
	06-61001-00-RP	Emergency floatation gear – Removable Parts	39.5	87.1
⚠ 06-67034-A	06-67034-00-CI	Emergency Locator Transmitter Kannad 121 AF-H ⁵	1.6	3.5
	Or	Or	or	or
⚠ 06-67035-A	06-67035-00-CI	Emergency Locator Transmitter Kannad 406 AF-H ⁶	1.6	3.5

Interior cabin layout

Document reference	Commercial reference	Name	kg	lb
⚠ 07-00006-B	07-00006-01-CI	STYLENCE cabin layout ⁷	29.2	64.3
⚠ 07-30001-A	07-30001-00-CI	Comfortable cabin upholstery ⁸	14.0	30.9
⚠ 07-30002-A	07-30002-00-CI	Reinforced soundproofing ⁹	5.2	11.5
⚠ 07-40001-A	07-40001-00-CI	Cabin carpet	4.3	9.5
⚠ 07-40002-A	07-40002-00-CI	Cabin washable cover	4.0	8.8
⚠ 07-60001-A	07-60001-00-CI	Cargo compartment upholstery	6.0	13.3
⚠ 07-74001-A	07-74001-00-FP	Foldable stretcher ¹⁰ – Fixed Parts	8.8	19.4
	07-74001-00-RP	Foldable stretcher – Removable Parts	13.6	30.0

¹ Recommended for training missions.

² Recommended for training missions on non-prepared airfield.

³ Recommended for sling work.

⁴ May be required for night VFR flight in some countries (operational regulations).

⁵ 2 frequencies : 121.5 MHz, 243 MHz. Compliant with ED 62 and TSO C91A.

⁶ 3 frequencies : 121.5 MHz, 243 MHz, 406 MHz. Compliant with ED 62 and TSO C91A.

The Programming Data Sheet must be filled and communicated by the customer two months at the latest before the helicopter's delivery. May be a mandatory equipment, required by local airworthiness authorities.

⁷ This layout includes the optional Comfortable cabin upholstery.

⁸ Cabin carpet, cabin washable cover and reinforced soundproofing are not included in the optional "Comfortable cabin upholstery".









⁹ "Reinforced soundproofing" needs the installation of the option "Comfortable cabin upholstery" or the "STYLENCE cabin layout".

¹⁰ For casualty transport, when the foldable stretcher is completely installed and the rear-bench and the communication panel are removed and left on ground, the overall weight of the helicopter is lighter by 8.4 kg (18.6 lb).

The data set forth in this document are general in nature and for information purposes only.

For performance data and operating limitations, reference must be made to the approved flight manual and all appropriate documents..

Avionics

Document reference	Commercial reference	Name	kg	lb
 08-00021-B	08-00021-01-CI	Avionics package <i>The avionics package includes :</i> VHF-AM n°2 Honeywell KY 196 ASC+ I.C.S. and passengers interphone Garmin GMA 340H ¹ Transponder Garmin GTX 330 (mode S) with altitude encoder Shadin 8800 T VHF-AM / VOR / LOC / GS / GPS Garmin GNS 430 ² Gyro-compass Honeywell KCS 55A with HSI KI 525A, and navigation coupling <i>The gyro-compass comprises :</i> - one directional gyro KG 102/102A with one magnetic azimuth transmitter KMT 112, - one slaving accessory KA 51, one HSI indicator KI 525A, one switch GPS/VOR, and one GPS caption panel - one coupling with the GPS Gyro-horizon with slip indication included Thales H321 EGM	20.8	45.9
 08-16011-A	08-16011-00-CI	I.C.S and passengers interphone Garmin GMA 340H	2.5	5.5
08-18016-A	08-18016-00-CI	Headset David Clark H10-13H ³	0.5	1.1
 08-21018-A	08-21018-00-CI	Radio-altimeter AHV 16 with indicator 201	5.6	12.3
 08-22034-A	08-22034-00-CI	Transponder Garmin GTX 327 instead of Garmin GTX 330 (Mode S) ⁴	-1.0	-2.2
 08-25002-A	08-25002-00-CI	D.M.E Honeywell KN 63 ⁴	2.0	4.4
 08-51003-A	08-51003-00-CI	Stand by Horizon Thales H321EGM, with stand by battery	5.0	11.0
08-62006-A	08-62006-00-CI	Vertical Speed Indicator in feet /mn United Instruments	0.4	0.9
08-83016-A	08-83016-00-CI	VEMD data download kit ⁵	0.0	0.0
 08-93001-A	08-93001-01-CI	Mechanical chronometer, Thommen with analog display	0.2	0.4
 08-93003-A	08-93003-00-CI	Quartz chronometer, Thommen with digital display	0.2	0.4

The avionics equipment weight figures included in this chapter are average values. As the installation of those equipment may vary from one a/c to an other, the weight of a complete configuration with multiple items may not be the simple sum of all individual weights.

- 1** *Mandatory optional to be proposed with, at least, 2 headsets.
The ICS plugs are available in US standard only and high level/high impedance.*
- 2** *A frequencies selector is fitted on the cyclic stick.
Delivered with Europe Navdata card. Subscription to be made by customer in good time for the helicopter delivery.*
- 3** *Quantity recommended = 2.*
- 4** *Requires the Avionics Package. May be a mandatory equipment, required by local airworthiness authorities.*
- 5** *This kit includes, two softwares and a connection wire.
This option requires the GNS 430 included in the Avionics package for full performance.*

*The data set forth in this document are general in nature and for information purposes only.
For performance data and operating limitations, reference must be made to the approved flight manual and all appropriate documents..*

5- Table of Constraints

EXL Impossibility of simultaneous fitment of the fixed parts of 2 items of equipment

NSF Total or partial incompatibility of simultaneous fitment of the removal parts of two items of equipment

NSU Possibility of simultaneous fitment on the same aircraft, but impossible to use simultaneously

REQ Requires the fitting of

Document Reference	Commercial Reference	Installation	Nature of the Constraint				Commercial Reference	Installation	Document Reference
			EXL	NSF	NSU	REQ			
05-02002-A	05-02002-00-CI	Aircraft without external painting	X				05-02028-00-CI	Landing gear customized paint	05-02028-A
			X				05-02033-00-CI	Two or three-color external painting instead of single color paint	05-02033-A
			X				05-2034-00-CI	Multicolor external painting (4 to 6 instead of single color paint)	05-02034-A
			X				05-02035-00-CI	Highly customized paint	05-02035-A
05-02028-A	05-02028-00-CI	Landing gear customized paint	X				05-02002-00-CI	Aircraft without external painting	05-02002-A
05-02033-A	05-02033-00-CI	Two or three-color external painting instead of single color paint	X				05-02002-00-CI	Aircraft without external painting	05-02002-A
			X				05-2034-00-CI	Multicolor external painting (4 to 6 instead of single color paint)	05-02034-A
			X				05-02035-00-CI	Highly customized paint	05-02035-A
05-02034-A	05-2034-00-CI	Multicolor external painting (4 to 6 instead of single color paint)	X				05-02002-00-CI	Aircraft without external painting	05-02002-A
			X				05-02033-00-CI	Two or three-color external painting instead of single color paint	05-02033-A
			X				05-02035-00-CI	Highly customized paint	05-02035-A
05-02035-A	05-02035-00-CI	Highly customized paint	X				05-02002-00-CI	Aircraft without external painting	05-02002-A
			X				05-02033-00-CI	Two or three-color external painting instead of single color paint	05-02033-A
			X				05-02034-00-CI	Multicolor external painting (4 to 6 instead of single color paint)	05-02034-A
05-42001-B	05-42001-01-CI	Air conditioning system	X				05-44001-00-CI	Cabin fan	05-44001-A
05-44001-A	05-44001-00-CI	Cabin fan	X				05-42001-01-CI	Air conditioning system	05-42001-B
06-11001-A	06-11001-00-FP	Skis	X				06-11003-00-FP	Long protective skid shoes	06-11003-A
			X				06-61001-00-FP	Emergency floatation gear	06-61001-A
06-11002-A	06-11002-00-CI	Short protective skid shoes	X				06-11003-00-CI	Long protective skid shoes	06-11003-A
06-11003-A	06-11003-00-CI	Long protective skid shoes	X				06-11001-00-FP	Skis	06-11001-A
			X				06-11002-00-CI	Short protective skid shoes	06-11002-A
06-61001-A	06-61001-00-FP	Emergency floatation gear	X				06-11001-00-FP	Skis	06-11001-A
06-67034-A	06-67034-00-CI	Emergency Locator Transmitter Kannad 121 AF-H	X				06-67035-00-CI	Emergency Locator Transmitter Kannad 406 AF-H	06-67035-A
06-67035-A	06-67035-00-CI	Emergency Locator Transmitter Kannad 406 AF-H	X				06-67034-00-CI	Emergency Locator Transmitter Kannad 121 AF-H	06-67034-A
07-00006-B	07-00006-01-CI	STYLENCE cabin layout	X				07-30001-00-CI	Comfortable cabin upholstery	07-30001-A
			X				07-40001-00-CI	Cabin carpet	07-40001-A
			X				07-40002-00-CI	Cabin washable cover	07-40002-A
			X				07-74001-00-FP	Foldable stretcher – Fixed Parts	07-74001-A
07-30001-A	07-30001-00-CI	Comfortable cabin upholstery	X				07-00006-01-CI	STYLENCE cabin layout	07-00006-B

The data set forth in this document are general in nature and for information purposes only.

For performance data and operating limitations, reference must be made to the approved flight manual and all appropriate documents..

Document Reference	Commercial Reference	Installation	Nature of the Constraint				Commercial Reference	Installation	Document Reference
			EXL	NSF	MSJ	REC			
07-30002-A	07-30002-00-CI	Reinforced soundproofing				X	07-30001-00-CI	Comfortable cabin upholstery	07-30001-A
						X	07-00006-01-CI	STYLENCE cabin layout	07-00006-A
07-40001-A	07-40001-00-CI	Cabin carpet	X				07-00006-01-CI	STYLENCE cabin layout	07-00006-A
			X				07-74001-00-FP	Foldable stretcher – Fixed Parts	07-74001-A
				X			07-40002-00-CI	Cabin washable cover	07-40002-A
07-40002-A	07-40002-00-CI	Cabin washable cover	X				07-00006-01-CI	STYLENCE cabin layout	07-00006-B
			X				07-74001-00-FP	Foldable stretcher – Fixed Parts	07-74001-A
				X			07-40001-00-CI	Cabin carpet	07-40001-A
07-60001-A	07-60001-00-CI	Cargo compartment upholstery	X				07-74001-00-FP	Foldable stretcher – Fixed Parts	07-74001-A
07-74001-A	07-74001-00-FP	Foldable stretcher – Fixed Parts	X				07-00006-01-CI	STYLENCE cabin layout	07-00006-B
			X				07-40001-00-CI	Cabin carpet	07-40001-A
			X				07-40002-00-CI	Cabin washable cover	07-40002-A
			X				07-60001-00-CI	Cargo compartment upholstery	07-60001-A
08-00021-B	08-00021-01-CI	Avionics package	X				08-16011-00-CI	I.C.S and passengers interphone Garmin GMA 340H	08-16011-A
08-16011-A	08-1611-00-CI	I.C.S and passengers interphone Garmin GMA 340H	X				08-00021-01-CI	Avionics package	08-00021-B
			X				08-22034-00-CI	Transponder Garmin GTX 327 instead of Garmin GTX 330 (Mode S)	08-22034-A
			X				08-25002-00-CI	D.M.E Honeywell KN 63	08-25002-A
08-21018-A	08-21018-00-CI	Radio-altimeter AHV 16 avec indicateur 201				X	08-00021-01-CI	Avionics package	08-00021-B
08-22034-A	08-22034-00-CI	Transponder Garmin GTX 327 instead of Garmin GTX 330 (Mode S)				X	08-00021-01-CI	Avionics package	08-00021-B
			X				08-16011-00-CI	I.C.S and passengers interphone Garmin GMA 340H	08-16011-A
08-25002-A	08-25002-00-CI	D.M.E Honeywell KN 63				X	08-00021-01-CI	Avionics package	08-00021-B
			X				08-16011-00-CI	I.C.S and passengers interphone Garmin GMA 340H	08-16011-A
08-51003-A	08-51003-00-CI	Std by Horizon Thales H321EGM, with std by battery.				X	08-00021-01-CI	Avionics package	08-00021-B
08-93001-A	08-93001-00-CI	Mechanical chronometer, Thommen with analog display	X				08-93003-00-CI	Quartz chronometer, Thommen with digital display	08-93003-A
08-93003-A	08-93003-00-CI	Quartz chronometer, Thommen with digital display	X				08-93001-00-CI	Mechanical chronometer, Thommen with analog display	08-93001-A

The data set forth in this document are general in nature and for information purposes only.
 For performance data and operating limitations, reference must be made to the approved flight manual and all appropriate documents..

Blank

*The data set forth in this document are general in nature and for information purposes only.
For performance data and operating limitations, reference must be made to the approved flight manual and all appropriate documents..*

6- Main performance

The following performance values and figures refer to an EC120B equipped with new engine. Unless otherwise specified, the values and figures refer to a clean helicopter at Sea Level (SL), in International Standard Atmosphere (ISA) and zero wind condition.

Gross Weight	kg	1,350	1,450	1,550	1,715	1,800¹
	lb	2,976	3,197	3,417	3,780	3,968
■ Max. speed, VNE ²	km/hr	278	278	278	278	-
	kts	150	150	150	150	-
■ Fast cruise speed	km/hr	236	233	230	223	-
	kts	127	126	124	120	-
■ Recommended cruise speed	km/hr	216	213	210	204	-
	kts	117	115	113	110	-
■ Fuel consumption at recommended cruise speed	kg/hr	97	97	97	97	-
	lb/h	213	213	213	213	-
■ Rate-of-climb	m/sec.	7.12	6.86	6.60	5.84	5.33
	ft/min.	1,400	1,350	1,300	1,150	1,050
■ Hover ceiling I.G.E. at Take-Off Power						
● Standard atmosphere	m	5,151	4,542	3,932	2,819	-
	ft	16,900	14,900	12,900	9,250	-
● standard atmosphere + 20°C	m	3,840	3,078	2,316	1,112	-
	ft	12,600	10,100	7,600	3,650	-
■ Hover ceiling O.G.E. at Take-Off Power						
● Standard atmosphere	m	4,785	4,115	3,444	2,316	899
	ft	15,700	13,500	11,300	7,600	2,950
● Standard atmosphere + 20°C	m	3,353	2,530	1,737	518	-
	ft	11,000	8,300	5,700	1,700	-
■ Service ceiling (Vz = 1 m / sec. – 200 ft/min.)						
● ISA	m	> 6,096	> 6,096	6,035	5,182	-
	ft	> 20,000	> 20,000	19,800	17,000	-
■ Maximum range (without fuel reserve, at recommended cruise speed)						
	km	680 ³	735	725	710	-
	n.m	367 ³	397	391	383	-
■ Endurance without reserve at the best endurance speed 65 knots	Hr : min	4h15 ³	4h30	4h27	4h19	-

1 In external load configuration.

2 The VNE is to reduce by 5 knots if Outside Air Temperature is ≤ - 35°C.

3 Takes into account 305 kg of fuel.

The data set forth in this document are general in nature and for information purposes only.

For performance data and operating limitations, reference must be made to the approved flight manual and all appropriate documents..

Operating limitations

The aircraft can be operated normally within the following altitude and temperature limitations :

- Maximum pressure altitude : 6,096 m – 20,000 ft
- Maximum temperature : ISA + 35° C, limited to + 50°C
- Minimum temperature : - 40° C

Remarks :

When equipped with appropriate optional equipment, the *EC120 B* is JAA certified for day and night VFR operations.

The operator shall check current operational regulations of the concerned country.

Abbreviations

IGE :	In Ground Effect
ISA :	International Standard Atmosphere
Vz :	Rate-of-Climb
OGE :	Out of Ground Effect
Zp :	Pressure Altitude

Units

n.m. :	nautical miles	hr:min :	hours:minutes
Kts :	knots	kg :	kilograms
ft/min :	feet/minute	lb :	pounds
m/sec :	meters per seconds	km :	kilometers
° C :	degrees Celsius		

*The data set forth in this document are general in nature and for information purposes only.
For performance data and operating limitations, reference must be made to the approved flight manual and all appropriate documents..*

Performance charts

The performance charts presented hereafter apply to an aircraft as per the standard definition.

■ Hover ceiling IGE (Height 5 ft) Maximum take-off power	Page 28
■ Hover ceiling OGE Maximum take-off power	Page 29
■ Fast cruise speed ISA	Page 30
■ Fast cruise speed ISA + 20°C	Page 31
■ Recommended cruise speed ISA	Page 32
■ Recommended cruise speed ISA + 20 °C	Page 33
■ Rate of climb ISA	Page 34
■ Rate of climb ISA + 20°C	Page 35
■ Hourly fuel consumption At fast cruise speed ISA, ISA + 20°C	Page 36
■ Hourly fuel consumption At recommended cruise speed ISA, ISA + 20°C	Page 37
■ Internal Payload Versus Range zp = 0 – ISA Recommended cruise speed	Page 38

*The data set forth in this document are general in nature and for information purposes only.
For performance data and operating limitations, reference must be made to the approved flight manual and all appropriate documents..*

HOVER CEILING I.G.E.

(Height 5 ft)

Maximum take-off power

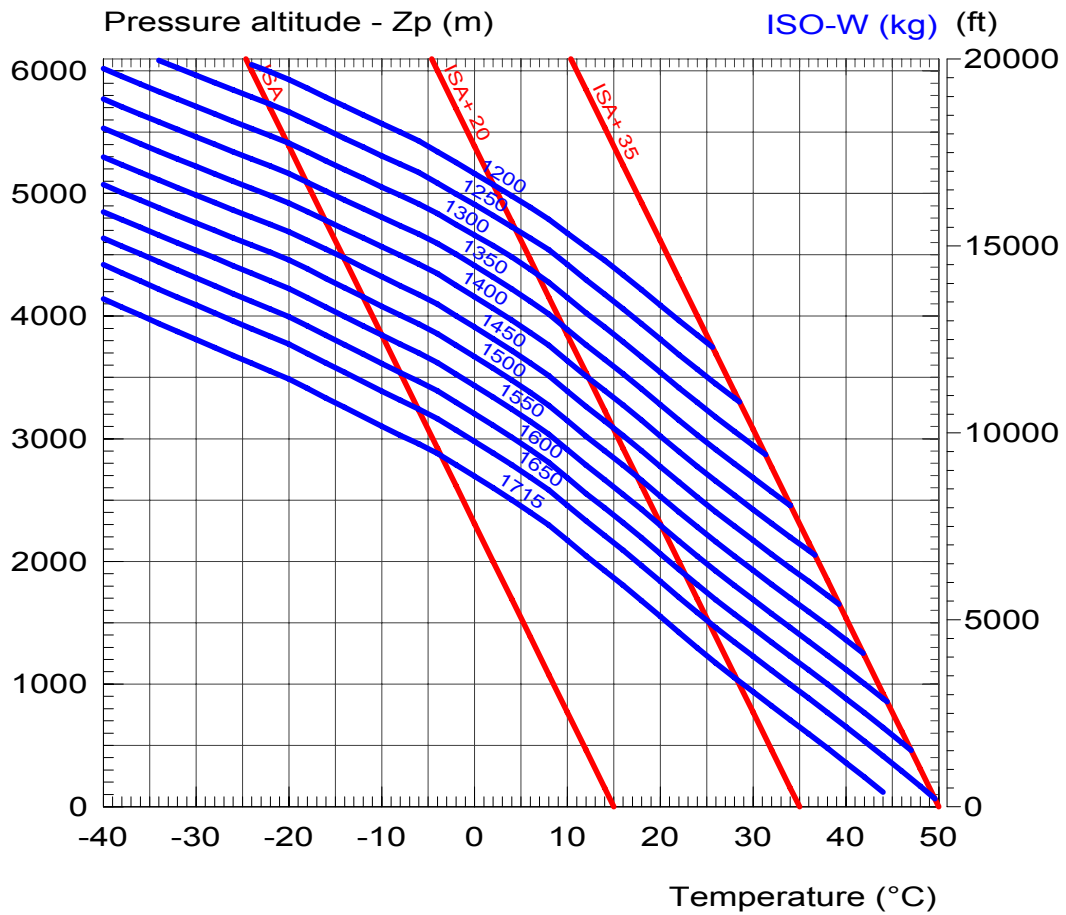

The data set forth in this document are general in nature and for information purposes only.

For performance data and operating limitations, reference must be made to the approved flight manual and all appropriate documents..

HOVER CEILING O.G.E.

Maximum take-off power

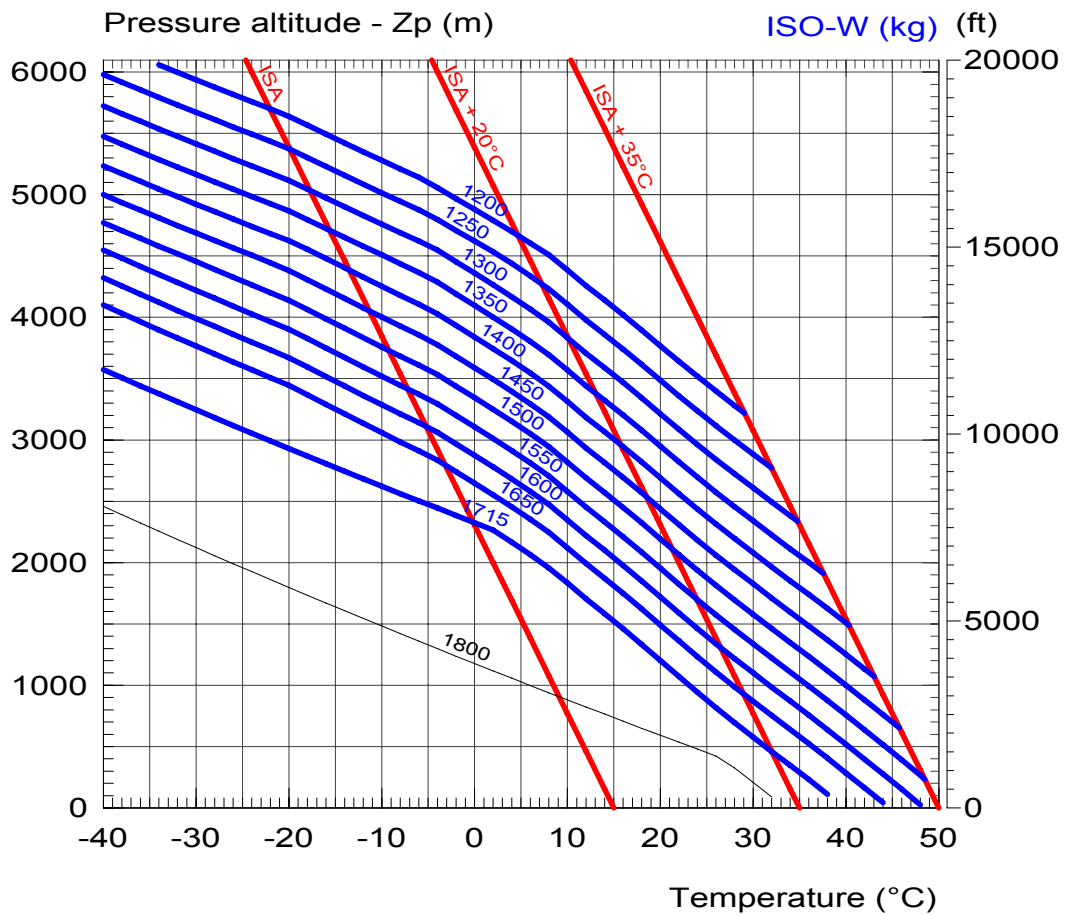

Note : ISO weight curve, at 1,800 kg is the curve with external load

*The data set forth in this document are general in nature and for information purposes only.
For performance data and operating limitations, reference must be made to the approved flight manual and all appropriate documents..*

FAST CRUISE SPEED

ISA

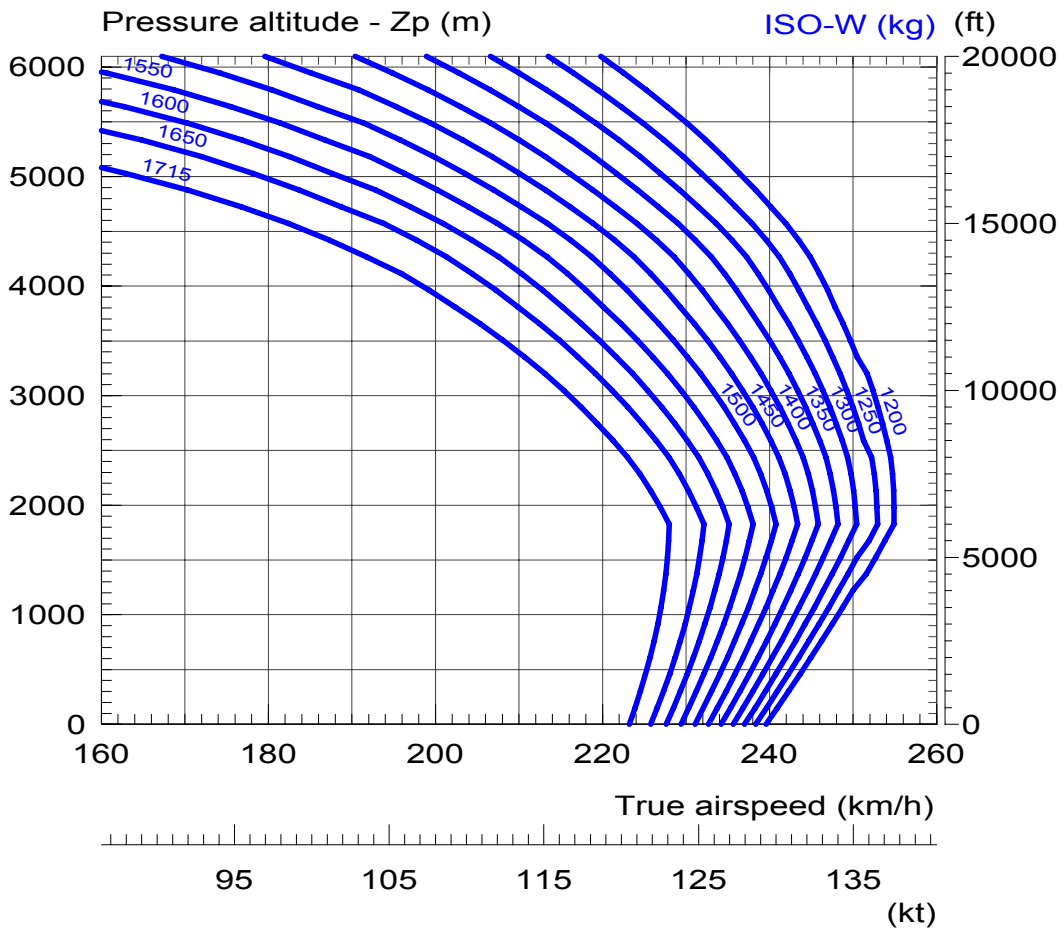

The data set forth in this document are general in nature and for information purposes only.

For performance data and operating limitations, reference must be made to the approved flight manual and all appropriate documents..

FAST CRUISE SPEED

ISA + 20°C

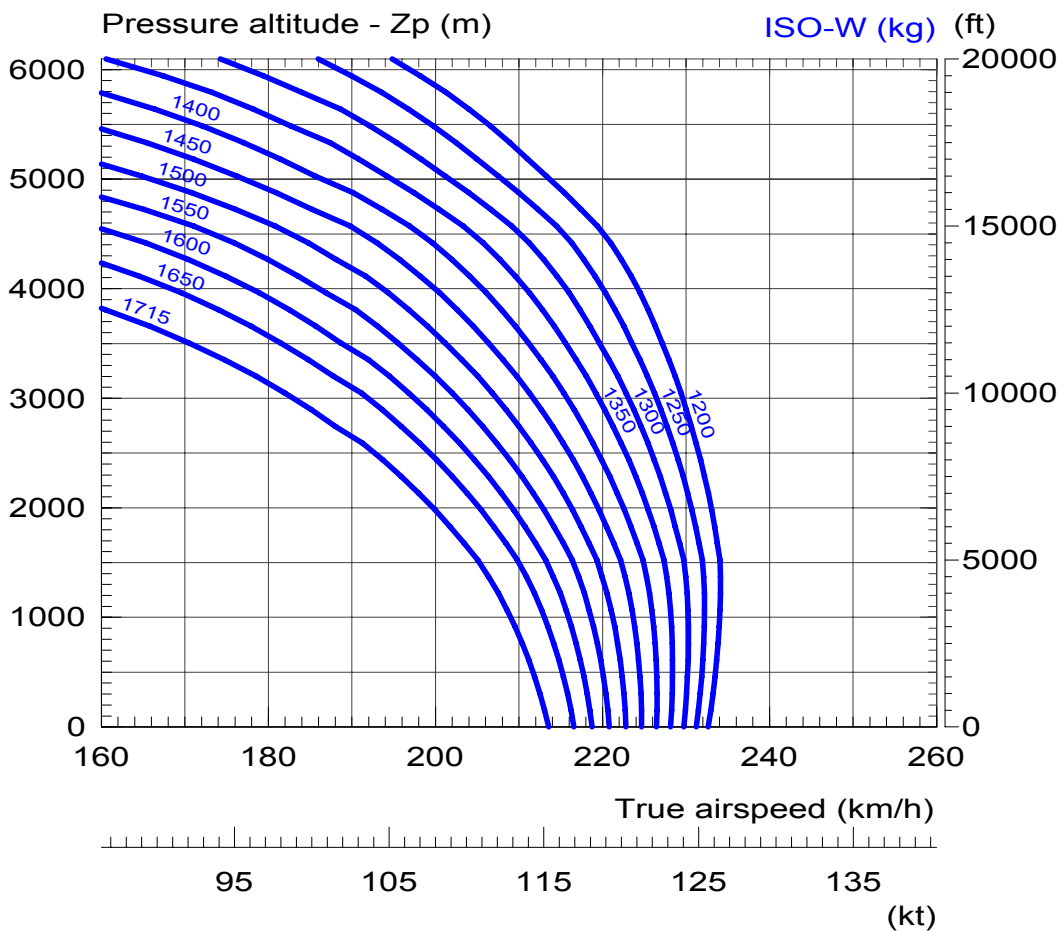

The data set forth in this document are general in nature and for information purposes only.
For performance data and operating limitations, reference must be made to the approved flight manual and all appropriate documents..

RECOMMENDED CRUISE SPEED

ISA

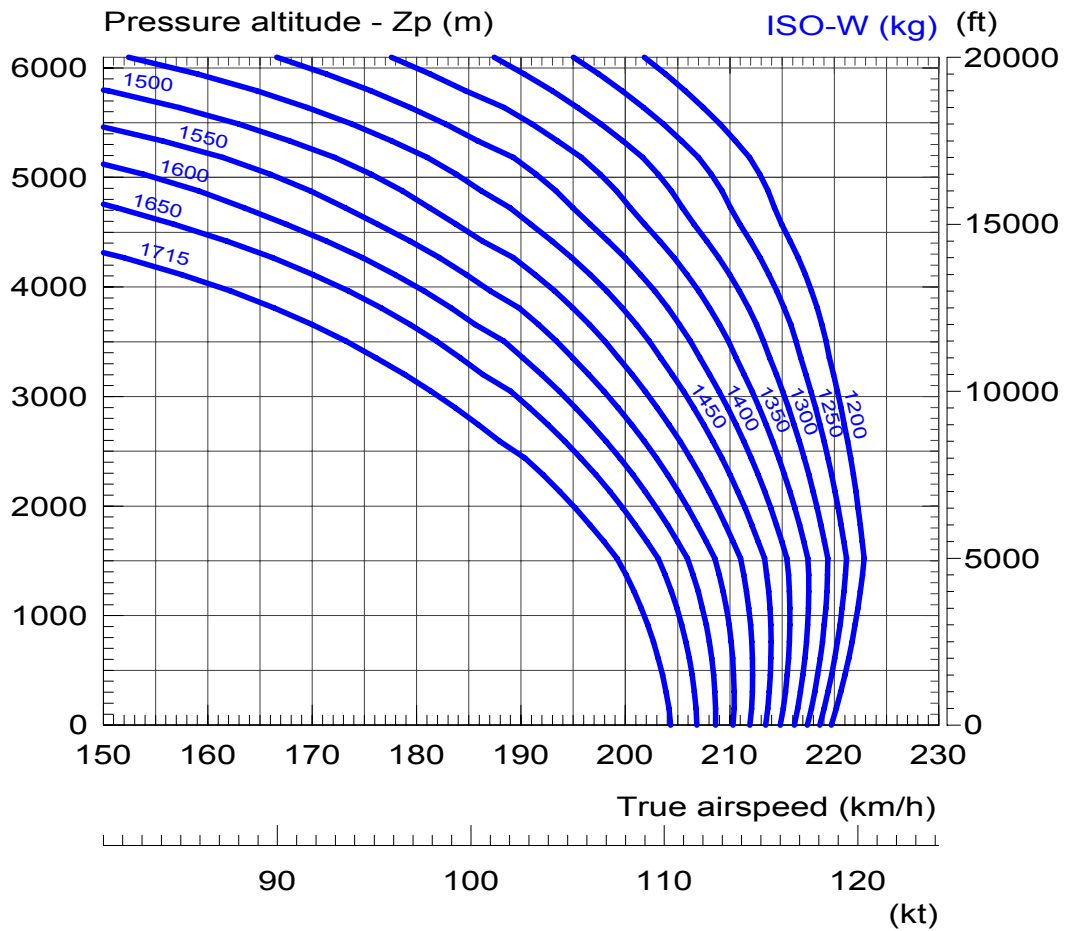

The data set forth in this document are general in nature and for information purposes only.
For performance data and operating limitations, reference must be made to the approved flight manual and all appropriate documents..

RECOMMENDED CRUISE SPEED

ISA + 20°C

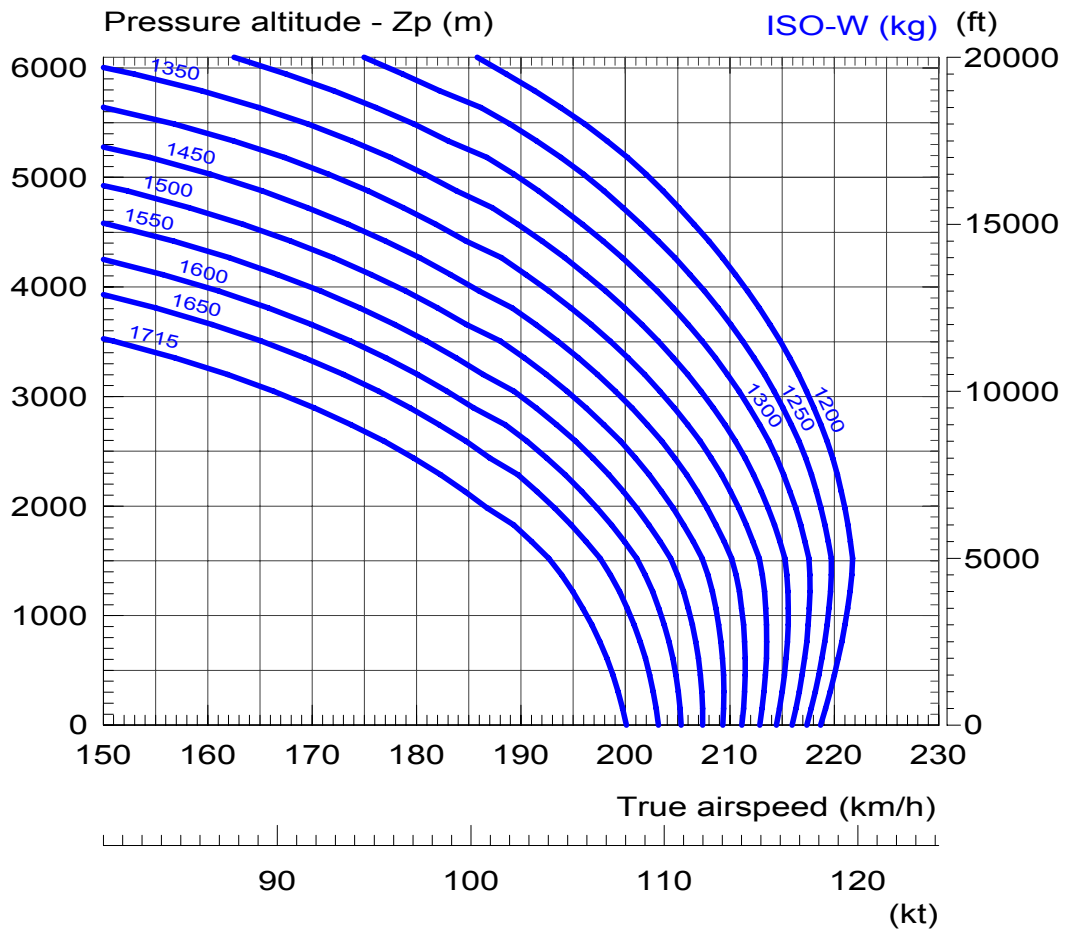

The data set forth in this document are general in nature and for information purposes only.

For performance data and operating limitations, reference must be made to the approved flight manual and all appropriate documents..

RATE OF CLIMB

ISA

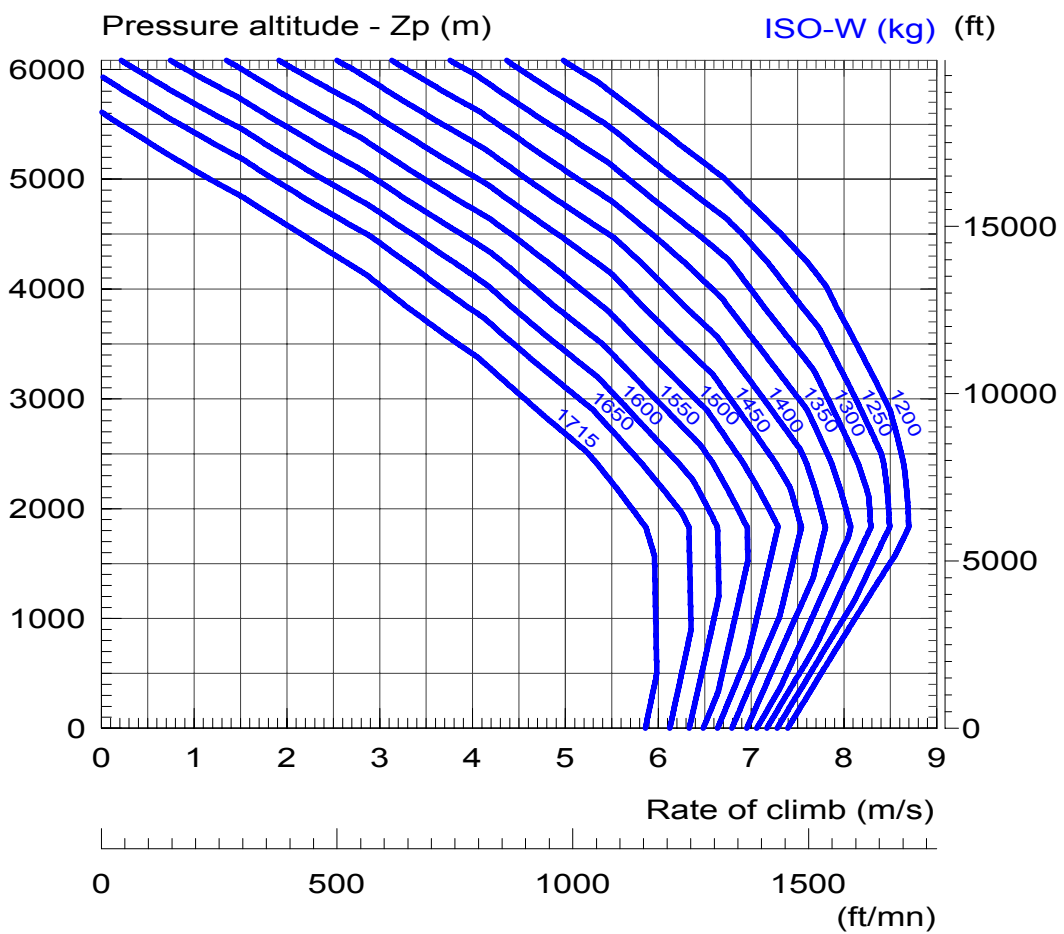

The data set forth in this document are general in nature and for information purposes only.
For performance data and operating limitations, reference must be made to the approved flight manual and all appropriate documents..

RATE OF CLIMB

ISA + 20°C

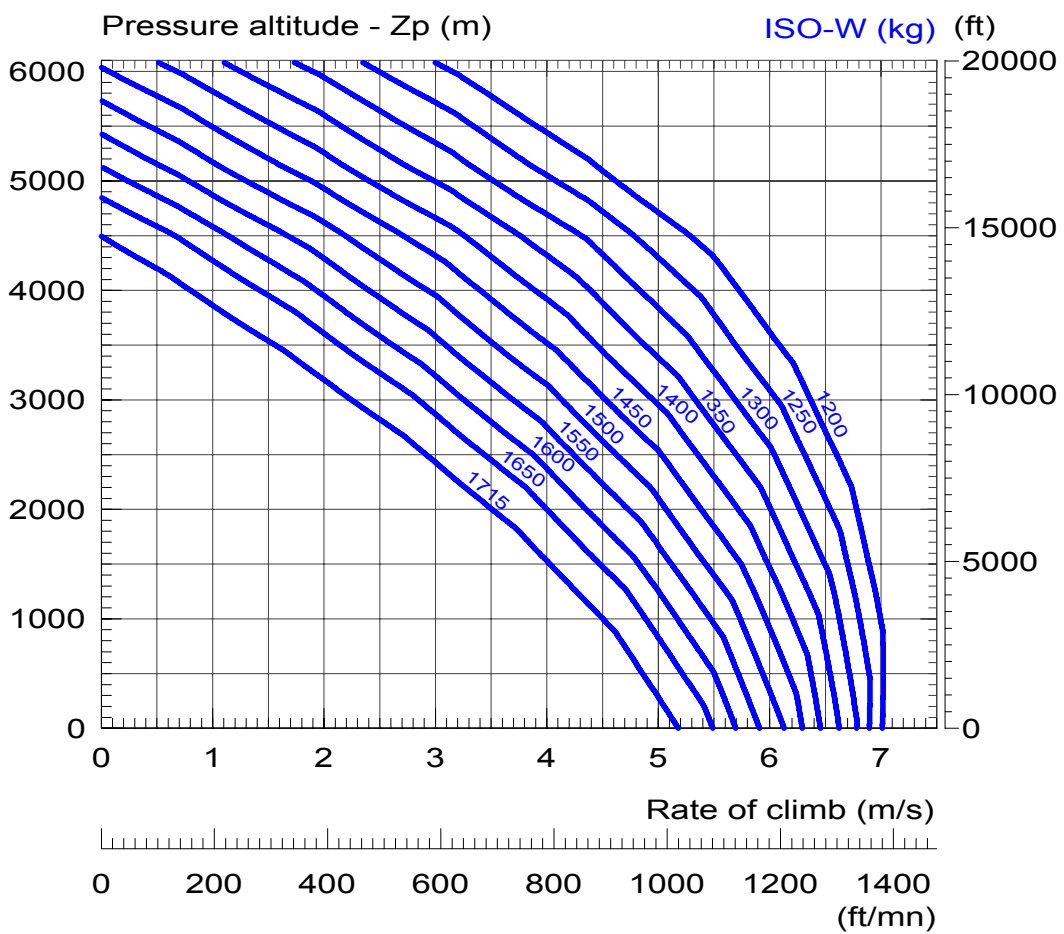

The data set forth in this document are general in nature and for information purposes only.
For performance data and operating limitations, reference must be made to the approved flight manual and all appropriate documents..

HOURLY FUEL CONSUMPTION

At fast cruise speed

ISA, ISA + 20°C

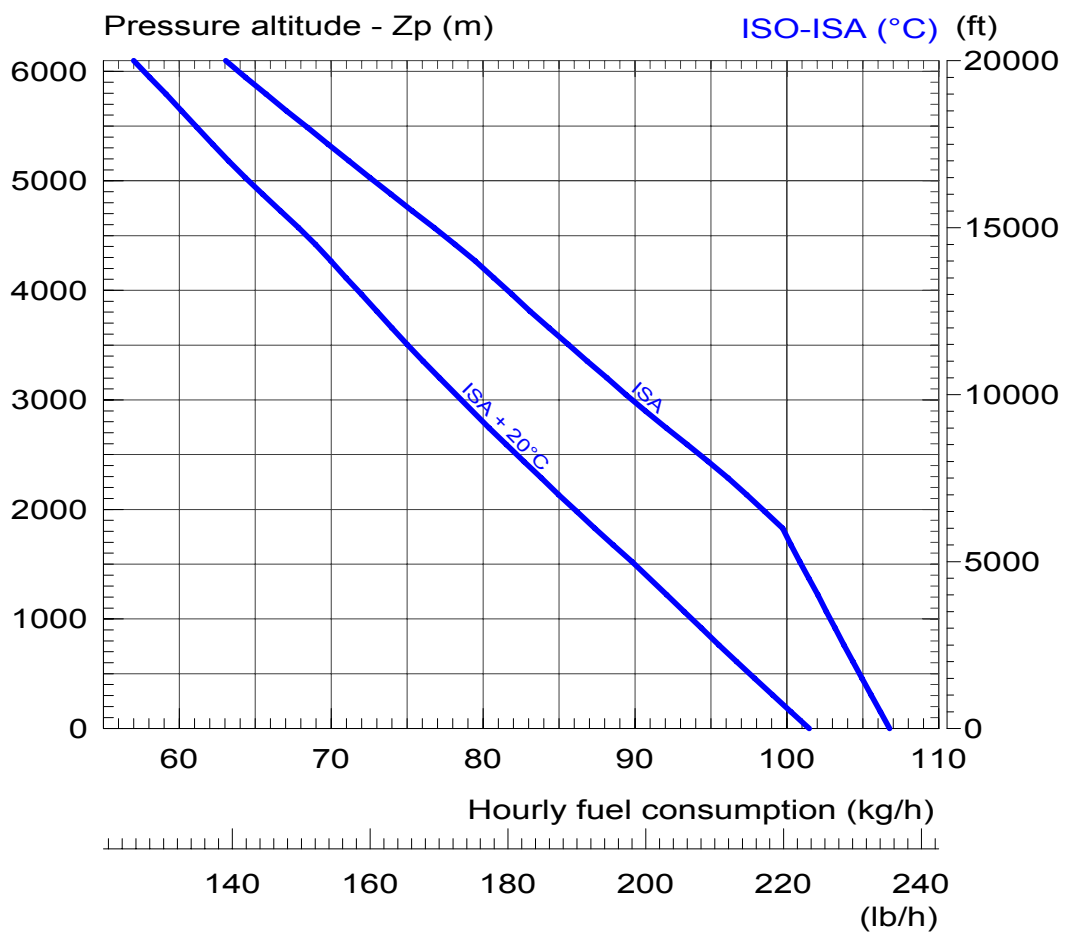

The data set forth in this document are general in nature and for information purposes only.

For performance data and operating limitations, reference must be made to the approved flight manual and all appropriate documents..

HOURLY FUEL CONSUMPTION

At recommended cruise speed

ISA, ISA + 20°C

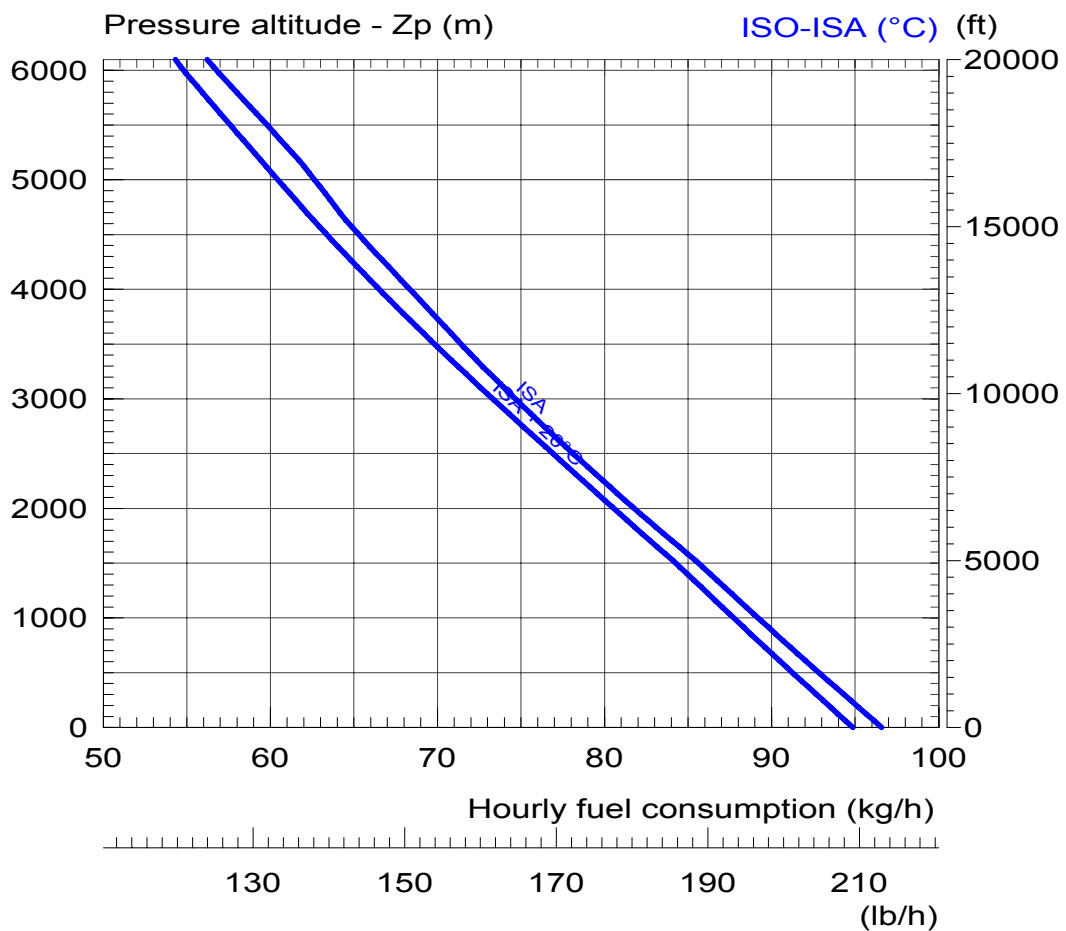

The data set forth in this document are general in nature and for information purposes only.

For performance data and operating limitations, reference must be made to the approved flight manual and all appropriate documents..

INTERNAL PAYLOAD VERSUS RANGE

Zp=0 - ISA

Recommended cruise speed

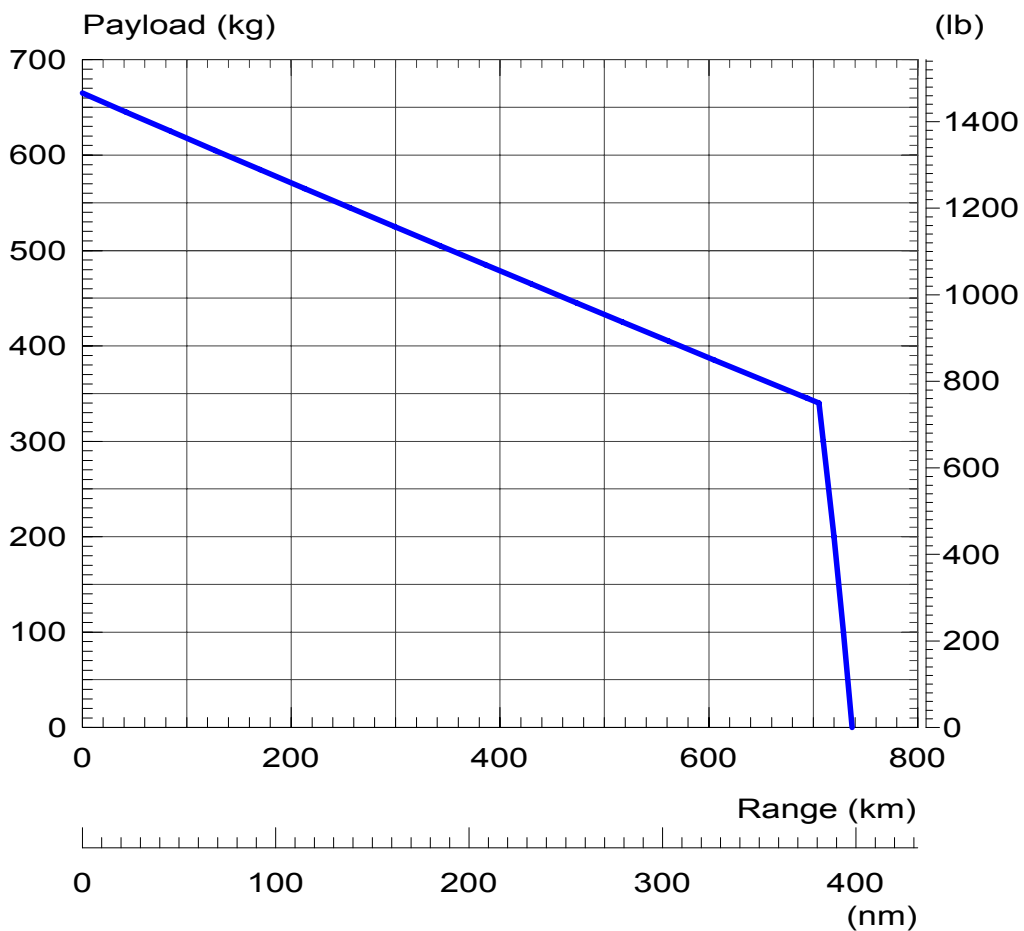

Note :

This curve is given for a maximum payload and fuel of 670 kg.

This value is the standard aircraft useful load (750 kg) less the pilot's mass (80 kg)

The data set forth in this document are general in nature and for information purposes only.

For performance data and operating limitations, reference must be made to the approved flight manual and all appropriate documents..

7- Customer Service Overview

Assets

Support concept has been considered during *EC120 B* design and development phases. It presents the following assets :

- Possibility to perform maximum of maintenance tasks by operators : part exchange offered to operators for engine and most of dynamic components e.g MGB (freewheel, gears, output for hydraulic unit), TGB (gears) and electrical heart modularity.
- Low required manhour on the scheduled maintenance confirmed by Customer's return of experience,
- Maintenance simple and easy to perform thanks to optimized accessibility to dynamic components and equipment,
- Among innovative equipment providing flight information, the "Vehicle and Engine Multifunction Display" (*VEMD*) also offers maintenance information (failure data recording and trouble-shooting information). Usage data may be downloaded on a lap-top for fleet data management, in compliance with some operational requirements.
- Limited number of tools,
- No test bench,
- Manufacturing of some tools by operator using technical publications supplied with the helicopter,
- Among technical publications, Master Servicing Manual has been written in such a manner that it can be directly used as a maintenance tasks repertory in the workshop.
- Specific VIP and corporate offer, called "Satisfly", covering full aircraft and engine maintenance package.

Maintenance and maintainability data

"Scheduled" and "unscheduled" maintenance (engine excluded) are considered in manhour figures given hereafter.

Scheduled maintenance

Possibility to perform maintenance tasks according to each operator needs :

- blocked whole inspection (helicopter unavailable during all the inspection duration),
or
- "splitted" inspection (helicopter available for flight since the inspection is performed in several batches of maintenance operations, in respect with the limitations and periodicities defined in the Master Servicing Manual).

*The data set forth in this document are general in nature and for information purposes only.
For performance data and operating limitations, reference must be made to the approved flight manual and all appropriate documents..*

Estimated Mean Man Hour per Flying Hour (MMH/FH) (standard aircraft/300 Flying hour/year – 2 flights per day)

0.70 MMH/FH (Scheduled + unscheduled + Service Bulletins implementation)

MMH/FH : Mean Man Hour per Flight Hour

Detail

■ Basic

● Flight-related checks :	Pilot's task up to 100 flight hours inspection	
● 100 flight hours or 12 months inspection Including average "corrective" works	2.6 hours 2.6 MMH for 100 flight hours	0.026 MMH/FH
● 500 flight hours or 24 months inspection Including average "corrective" works	103 MMH per inspection 103 MMH for 500 flight hours	0.205 MMH/FH
● 1500 flight hours or 72 months inspection Including average "corrective" works	51 MMH per inspection 51 MMH per 1500 flight hours	0.034 MMH/FH
● 144 months inspection Including average "corrective" works	300 MMH	0.083 MMH/FH

■ **Unscheduled (reliability cause) 0.30 MMH/FH**

■ **Service Bulletins implementation 0.05 MMH/FH**

MMH : Mean Man Hour,

The data set forth in this document are general in nature and for information purposes only.

For performance data and operating limitations, reference must be made to the approved flight manual and all appropriate documents..

Time Between Overhaul (TBO) / Service Life Limit (SLL)

Major assemblies	TBO (hr)	SLL (hr)
Main Blade		20000
Rear Blade		8500
MGB		
■ Epicyclic reduction gear + Mast/Hub	3750	
■ Main module, MGB	3750	
Complete engine	3500 ¹	
TGB	3750	
Main servo-unit	4000	

1 : Target value

Documentation

EUROCOPTER EC120 B technical documentation, pleasant and easy to consult, is basically supplied:

- **On an Interactive Electronic Support (CD-ROM INDOC-EC120) provided free of charge with a twice a year update**, that includes the whole documentation : Operating (except Flight Manual), Maintenance, Identification and Specific documents.

The CD-ROM product presents great advantages such as :

- More efficiency in maintenance thanks to :
 - ◆ Direct and instantaneous access to manuals and data by "hypertext" navigation
 - ◆ Easy search by keywords and multiple criteria
 - ◆ Highly portable technical publications in an extremely compact format
- Quick updating without insertion mistake risk.

and

- **On paper**
 - Flight Manual
 - Other documents : Master Servicing Manual , Wiring Diagrams Manual, Service Bulletins.

Note : 1. As an option , the whole EUROCOPTER documentation is available on paper.

2. Turbomeca ARRIUS 2F engine technical documentation is available both under CD-ROM and paper format.

The data set forth in this document are general in nature and for information purposes only.

For performance data and operating limitations, reference must be made to the approved flight manual and all appropriate documents..

Blank

*The data set forth in this document are general in nature and for information purposes only.
For performance data and operating limitations, reference must be made to the approved flight manual and all appropriate documents..*